



**INSTALLATION, OPERATION &
MAINTENANCE INSTRUCTIONS FOR :-**

SERIES AH, AHW, IDG, DGF & PVU

AIR HANDLING UNITS

CONTRACT No :	
PROJECT REF :	



AIR HANDLERS LIMITED.
Alfred Proctor House, Bute Street
Weaste, Salford, M50 1DU
TEL :- 0161 745 8888 FAX :- 0161 925 9900

<mailto:enquiries@airhandlers.net>

HEALTH and SAFETY

Working Conditions and Pre-Installation Check

This section deals with the hazards that could be encountered when any work is carried out on the equipment for which this manual is written.

Therefore the following points should be observed to avoid any injuries or health hazards.

The unit shall be checked to ensure that :

- ❑ It is suitable for the electrical supply available.
- ❑ It is suitable for the atmosphere or the environment in which it is to be used.
- ❑ It is suitable for the working media, temperature and pressure for which it is to be used.
- ❑ If the unit is situated in a confined space, suitable ventilation **MUST** be available to ensure that any media used (such as ammonia, R22 or R407C) is not injurious to health.
- ❑ It is manually isolated from the mains supply before any work is carried out. **DO NOT** enter the unit while the fans are running.
- ❑ Electrical equipment is earthed to comply with I.E.E. regulations and local by-laws.
- ❑ When starting the electric motor(s) the procedure as laid down in this manual is fully carried out.
- ❑ The procedure for removing and replacing timing/wedge belts and filter media (bags or panels) are fully carried out as laid down in this manual or the suppliers literature.

CAUTIONARY NOTES

No part of the unit shall be dismantled until a careful study has been made of this manual.

This manual deals in detail with erection, commissioning and servicing and shall be strictly adhered to.

Wherever any maintenance or work is done within the unit, the interior shall be left clean and all access panels shall be correctly fastened.

Bearing Damage – Cautionary Note

During the interval between delivery and commissioning the drive belts should be slackened and the fan and motor shafts rotated one quarter of a revolution at intervals of once a week.

Water Treatment (Mandatory)

Check for any treatment that is required to the water supply for prevention of corrosion and scaling of equipment. Information regarding the necessary action to be taken can be obtained from the relevant Water Supply Authority, particulars of which can be found in the Waters Engineers Handbook yearly edition.

DELIVERY

Upon receipt of equipment a visual inspection should be made and any damage noted on the delivery form. Particulars of any damage or short delivery should be endorsed by the driver delivering the equipment. No responsibility can be held for damage sustained during the unloading from the delivery vehicle or on the site thereafter.

All claims for damage or short delivery should be advised to AIR HANDLERS NORTHERN LTD. in writing within five (5) days of receipt.

OFF LOADING and HANDLING

Each assembly is only to be lifted at the four (4) points when provided on the channel base. For smaller units nylon straps of the correct capacity should be used. Spreaders must be used to prevent any damage when lifting using slings or lifting points.

ERECTION of UNIT

Before mounting unit in position it is advisable that consideration is given to the access requirements of the unit, particularly with reference to the following :

That provision is made in the plant room or wherever the unit is to be installed for access to remove the following components :

- Fans
- Electric Heater Batteries
- Filters (bags or panels)
- Coils and Pipework

Access space is also essential for service and maintenance purposes, and for the removal of the motor(s).

INSTALLATION

All units must be installed in accordance with good engineering standards, upright and levels on a prepared base. Fixing down of air handling units is at the discretion of the installer and dependant of the site conditions.

Flexible connections are NOT recommended for connecting ductwork to the unit, as the fan outlet is fitted with a flexible connector, and is isolated from the unit via anti-vibration mounts.

Provision must be made for a cleanable drain trap which should terminate at an open drain or tundish which will ensure any blockage can be seen and remedied.

Units that are delivered in sections should be carefully checked with the general arrangement drawings to ensure erection in the correct sequence and handing. The sections would be bolted together using the nuts, bolts and sealant provided.

ELECTRICAL INSTALLATION

Site wiring must not penetrate or restrict opening or removal of access panels.

COMMISSIONING and TESTING

All units should be commissioned before initial operation by the contractors appointed engineer. Pre-start checks are required in accordance with recommendations laid down in these instructions. After completion of commissioning all bolts should be tightened and drives checked for alignment and tension.

MAINTENANCE OF EQUIPMENT HELD IN STORAGE CONDITIONS FOR A PERIOD UP TO 2 YEARS

Unit Interior and Exterior Surfaces

Interior

If ducting is not connected it is essential that all inlets and discharge openings are completely sealed.

Exterior

The exterior shall be kept free from falling building materials, dampness or extreme cold or heat. The unit exterior surfaces should be inspected on a monthly basis and any sign of corrosion or scratches are to be treated immediately.

Static Indentation

Machines fitted with ball bearings may be damaged if left stationary for long periods. The balls and races may suffer damage by fretting corrosion (false brinelling, stationary vibration or static vibration marking).

Wedge Belts and Pulleys

Wedge belts should be removed from the pulleys and hung up and not exposed to excessive heat or cold and kept free from dampness. Belt life is reduced over a long period of non-use due to the curing and static condition of rubber.

Pulleys already taper-locked to shafts can be lightly covered with rustproof compound. This must be thoroughly cleaned off before belting up prior to start up.

Filters

All filters, whether in the form of bags or panels, must be suitably wrapped and sealed to prevent damp and ingress of dust or foreign bodies, and held in a dry store.

Fan Shaft Bearings

Refer to Bearing damage in Cautionary Notes. Bearings fitted with shields should not be stored for periods exceeding two (2) years since the grease ages. Bearings stored for longer periods than that specified may be found to have a higher initial starting torque and the service life of the grease will then be shortened. It is therefore advisable to repack the grease after twelve months of non use. Fan shafts and impellers should be protected with rustproof compound to prevent any corrosion taking place.

Electric Motors

Clean out all the dust accumulated inside and outside the motor and make sure that all the component parts of the motor are in good condition. Cover all the ventilating holes on the motor frame to prevent dust from entering the motor. Apply a coating of anti-corrosion grease or other anti-corrosion agent on all the parts that may be subject to rusting. Care must be taken to see that the storeroom is always dry and well ventilated while the room temperature is regularly maintained above 0°C. During storage, periodic inspections should be made to check for moisture, rust or hardening of grease.

The above are intended to preserve the life of all static and moving parts of the equipment during the period of storage. It is advisable that regular attention of the equipment is maintained.

FAN SECTION

Pre-Start Checks

After assembly of Air Handling unit the following checks should be made. Refer to Data Chart on General Arrangement drawing for specific details.

Isolate electric supply to fan-motor before entering the fan section.

- Check pulleys/bushes are secure on shafts and that key is fitted.
- Check belt tension, see drivebelt section of this manual for directions.
- Check that anti-vibration mountings are level and that bolts are tight
- Check motor terminal cover is secure and that bolts are tight.

Test Run

Test run the motor and drive to ensure that the fan is rotating in the right direction. The correct rotation direction is marked on the fan scroll. If the rotation is in reverse, stop the motor and reverse any two (2) incoming supply lines to the motor or starter (3 phase supply).

Check that the current being drawn by the motor does not exceed the motor full load current (indicated on the motor name plate). Note! All access panels must be closed during this test, otherwise false readings will be obtained.

After 30 minutes operation drive belts should be checked for tension and re-tensioned if required.

Maintenance

At least every 12 months a major inspection of the fan section should be carried out as follows:

- Isolate electric supply to fan-motor.
- Remove and examine drivebelts, check for uneven wear in belts which could indicate misalignment of pulleys or possible wear to fan bearing.
- Rotate and rock shafts of fan and motor to detect bearing play.
- Clean fan impeller, any build-up of grease and dust will affect the balance of the fan causing stresses and decreasing the bearing life.
- Inspect all internal and external surfaces for signs of deterioration.
- After Inspection and replacement carry out pre-start check and test run.

Fan Maintenance

Frequent inspection should be made of the fan.

General inspection of the fan will depend on how essential the service, the application operating environment and number of hours run, but should not be more than three monthly intervals.

On fans operating in dusty atmospheres or exposed to weather then the bearing will need to be flushed out and replenished with grease every six months.

Recommended Lubricants

Standard fan bearings :- Shell Alvania Grease 3 (or equivalent)

Hot Gas fan bearings :- Shell Alvania Grease RA (or equivalent)

ELECTRIC MOTORS

It is advisable to have a monthly inspection of the motor operation.

Regular cleaning of the motor is necessary during it's service. Care must be taken to prevent moisture, dust, etc from entering the motor.

Ensure that adequate grease lubrication is provided for the bearings when the motor is in operation. Grease lubricant should be in general replaced every 6 months or immediately under the following conditions.

- ❑ Lubricant grease hardened or darkened.
- ❑ Accumulation of water drops, dust or dirt on the grease surface.
- ❑ Overheating of the bearings.

When replacing the grease, the bearings should be cleaned and rinsed thoroughly with gasoline or kerosene after the old grease has been cleaned out. The bearing housing should then be filled with new grease to 2/3 of its volume. This is very important as impaired lubrication will result from insufficient or excessive grease.

Built-in lubricating cups and grease relief holes are provided inside both end brackets Ball-bearing motors are shipped with sufficient grease for a long operating period, if relubrication is needed, using a low pressure hand-operated grease gun, pump in clean recommended grease until the new grease appears at the relief hole.

DRIVE BELTS

Belts should be examined each month for tension, alignment and any signs of wear. If one belt in a matched set is found to be damaged the whole set is to be changed.

Extreme care must be taken when tensioning belts, excessive tension will cause overloading of bearings and cause damage to bearings, shafts & belts.

Insufficient tension will cause belts slip leading to excessive noise and belt wear.

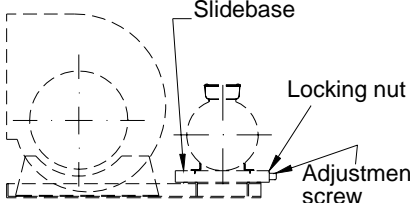
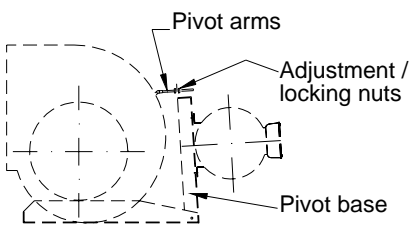
<p style="text-align: center;">SLIDE BASE ARRANGEMENT</p>  <p>The diagram shows a motor shaft with a slidebase. An adjustment screw is attached to the slidebase, and a locking nut is used to secure it. Labels include 'Slidebase', 'Locking nut', and 'Adjustment screw'.</p>	<ul style="list-style-type: none"> ◦ Undo locking nut to release adjustment screw. ◦ Rotate adjustment screw in required direction to tension/slacken belts. (For tensioning of belts see directions). ◦ After adjustment re-tighten locking nut.
<p style="text-align: center;">PIVOT BASE ARRANGEMENT</p>  <p>The diagram shows a motor shaft with pivot arms. Adjustment/locking nuts are used to adjust the angle of the pivot base. Labels include 'Pivot arms', 'Adjustment / locking nuts', and 'Pivot base'.</p>	<ul style="list-style-type: none"> ◦ Adjust angle of pivot base along arms to tension/slacken belts (For tensioning of belts see directions). ◦ Ensure pivot base is square with fan and motor/fan shafts are parallel. ◦ After adjustment re-tighten locking nuts on both arms.

BELT TENSIONING INSTRUCTIONS

Tensioning Forces

Belt Section	Force required to deflect belt 16mm per metre of span	
	Small Pulley Diameter	Kilogram Force
SPZ	56-95 mm	1.3-2.0 kg
	100-140 mm	2.0-2.5 kg
SPA	80-132 mm	2.5-3.6 kg
	140-200 mm	3.6-4.6 kg
SPB	112-224 mm	4.6-6.6 kg
	236-315 mm	6.6-8.7 kg
SPC	224-355 mm	8.7-11.7 kg
	375-560 mm	11.7-15.3 kg

Belt Tensioning Procedure Using A Belt Tension Indicator

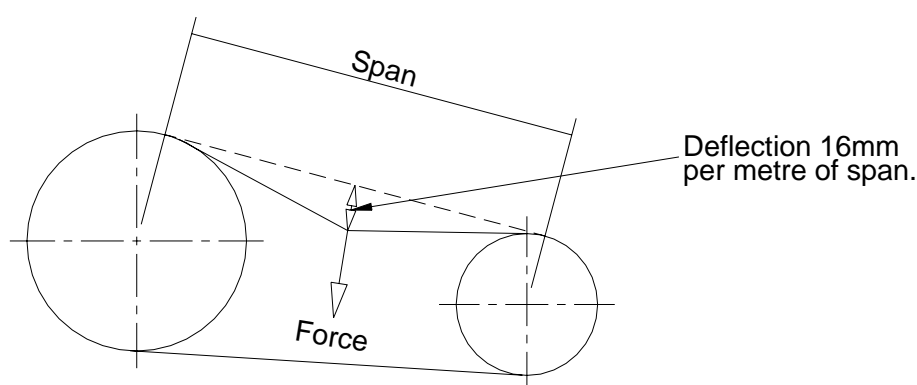

- ❑ Calculate the deflection distance in mm on a basis of 16mm per metre of centre distance.
- ❑ Set the lower marker ring at the deflection distance required in mm on the lower scale.
- ❑ Set the upper marker ring against the bottom edge of the tube.
- ❑ Place the belt tension indicator on top of the belt at the centre of the span, and apply a force at the right angles to the belt deflecting it to the point where the lower marker ring is level with the top of the adjacent belt.
- ❑ Read off the force value indicated by the top edge of the marker ring.
- ❑ Compare this force to the kgf value in the table above.
- ❑ If a Belt Tension Indicator is not available, a spring balance and rule will suffice.

Important

AFTER THE DRIVE HAS BEEN RUNNING FOR APPROXIMATELY 30 MINUTES, THE TENSION SHOULD BE CHECKED AND RE-ADJUSTED TO THE HIGHER VALUE , IF NECESSARY.

ELECTRIC AIR HEATER BATTERIES

These should be wired up in accordance with I.E.E. Regulations and local by laws. It is essential that the heater contactor is interlocked with the fan starter to prevent the heater being energised when the fans are not running. Additionally it is recommended that a fan run on facility is included within the controls to dissipate heat from the battery at the end of operation. All heater batteries incorporate a safety cut-out which must be wired into the controls system. Ensure the size of cable and contactors are suitable for load being carried. It is not recommended for P.V.C. cable to be run into the terminal box. The cable should be insulated with high temperature sleeving.

HEATING and COOLING COILS

General

Coils are normally designed as either cartridge arrangement where they are fitted inside the casework of the air handling unit, or bolted directly between two sections of the AHU. All LPHW and chilled water coils are fitted with an air vent and drain plug on the header connections.

Drain Connections

All cooling coils include a condensate drain tray fitted with a drain connection to be connected to an appropriate trapping system. Care must be taken to ensure that the correct type of drain trap is used depending on positive / negative air pressure within the coil section. Drain lines from the trap must be pitched downwards, a slope of 1 : 25 is recommended.

Installation & Maintenance of Coils

During installation care must be taken to prevent damage being caused to fins, tubes, headers & return bends of the coil. Damage to fins can be corrected by use of a fin comb (available from Air Handlers) all coils should be installed level and upright, unless otherwise specified. Care must be taken to ensure the following conditions are satisfied :-

- ❑ Water flow & return connections are correctly connected.
- ❑ All connecting Pipework is independently supported with adequate mountings.
- ❑ Any pipe movement caused by expansion or contraction must be absorbed by flexible joints.
- ❑ Coils located at high points of the system should be regularly vented, other wise coils may become air locked causing a reduction in duty.
- ❑ When connecting screwed fittings, it is necessary to restrain the back nut to avoid damage to the coil.

Coils should be inspected every three(3) months to check for build up of foreign matter between the fins, and that coil and connections are free from leaks. Should any foreign matter be found cleaning should be carried out with a high pressure air line directed at the air off face of the coil. Alternatively the coil can be washed down with a mild solution of detergent and water, after which the coil should be thoroughly rinsed with clean water.

Eliminators should be cleaned down using a soft brush and hot water, any sediment cleared out of drain tray and drain pipe, and if necessary repair any areas of corrosion.

Condensate Removal From Steam Coils

When air, water, or another product is heated, the temperature or heat transfer rate can be regulated by a modulating steam pressure control valve. Since pressure and temperature do not vary at the same rate as load, the steam trap capacity, which is determined by the pressure differential between the trap inlet and outlet, may be adequate at full load, but not at some lesser load.

Analysis shows that steam pressure must be reduced dramatically to achieve a slight lowering of temperature. In most applications this can result in sub-atmospheric pressure in the coil, while as much as 75% of full condensate load has to be handled by the steam trap. This is especially important for coils exposed to outside air, since sub-atmospheric conditions can occur in the coil at outside temperatures below 32°F (0°C) and the coil will freeze if the condensate is not removed. There are detailed methods for determining condensate load under various operating conditions. However, on most cases, this load does not need to be calculated if the coils are piped as shown in the figure below and this procedure is followed.

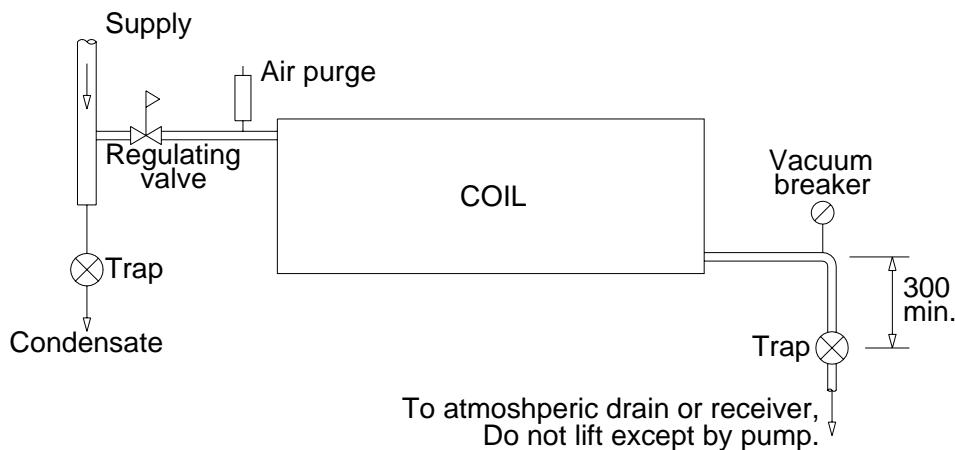

The steam trap should be 1 to 3ft (0.3 to 0.9m) below the bottom of the steam coil to provide a hydraulic head of approximately 0.5 to 1.5 psig (3.5 to 10.3kpa above atm.). Location of the trap at less than 12in (300mm) minimum usually results in improper drainage and operating difficulties.

- Vacuum breakers must be installed between the coil and the trap inlet to ensure that the hydraulic head drain the coil when it is at atmospheric or sub-atmospheric pressure. The vacuum breaker should respond to a differential pressure of no greater than 3in. of water (750pa). For atmospheric returns, the vacuum breaker should be opened to the atmosphere, and the return system must be designed to ensure no pressurization of the return line. In vacuum return systems, the vacuum breaker should be piped to the return line.
- Discharge from the trap must flow by gravity, without any lifts in the piping, to the return system, which must be vented properly to the atmosphere to eliminate any back pressure that could prevent the trap from draining the coil. Where the return main is overhead, the trap discharge should flow by gravity to a vented receiver, from which it is then pumped to the overhead return.
- Traps must be designed to operate at maximum pressure at the control valve inlet and sized to handle the full condensate load at a pressure differential equal to the hydraulic head between the trap and coil. Since the actual condensate load can vary from the theoretical design load because of the safety factors used in coil selection and the fact that condensate does not always form at a uniform steady rate, steam traps should be sized according to the following:-

0-15psig (0-100kpa above atm.) at the control valve inlet: size the trap for twice the full condensate load (coil condensing rate at maximum design conditions) at 0.5psi (3kpa) pressure differential.

16-30psig (110 to 200kpa above atm.) at the control valve inlet: size the trap for twice the full condensate load at 2psi (14kpa) pressure.

31psig (210kpa above atm.) and over at the control valve inlet: size the trap to handle triple the full condensate load at a pressure differential equal to half the control valve inlet pressure.

- ❑ The steam supply must be drained of entrained condensate prior to entering the coil, preferably, just before the regulating valve.

RECUPERATORS

Maintenance

Recuperator units have no moving parts, hence mechanical maintenance is unnecessary. When dealing with dusty and polluted air, filters should be regularly checked and replaced when necessary. It is possible to clean the unit with compressed air (in case of dust deposit) or by spraying it with a detergent solution in case of any greasy deposits.

In order to remove greasy deposits, a water-detergent solution such as DECADE, ND-150 CHEM ZYME, PRIMASEPT, POLY-DET, oakite 86m or similar should be used, following the manufacturers instructions.

Strongly alkaline or any products that may be aggressive to aluminium should be avoided.

DAMPERS

Installation

When connecting ductwork to dampers take care to ensure that damper casing is not twisted by ductwork and that fixings do not penetrate cog housing of the damper which will affect the damper mechanism. Ductwork must be independently supported and should not be left to hang from the damper. Sealing should be in the form of prestik or neoprene strip.

Ensure actuator rotation is correct in relation to blade location to prevent breaking linkages.

Maintenance

At six (6) month intervals disconnect actuator and check for freedom of movement.

AIR FILTERS

COSHH Regulations

The components of filters are inherently safe, but changing air filters could expose operators to a 'Nuisance Dust' hazard. We would therefore recommend that filter changing be carried out by maintenance personnel wearing simple dust masks, eye protection, overalls or protective clothing & gloves. Dirty filters should be sealed into plastic bags for disposal.

Disposable Filters

These are supplied in the forms of panel & bag filters and are fitted into steel channel runners. Filters are simply withdrawn through the access door by sliding the filter along the channel runner. Filters should generally be replaced when the pressure drop increases to 0.5"wg (125pa) above the initial level.

Washable Panel Filters

Generally as per disposable filters except when pressure drop indicates dirty filter conditions, filters should be fully immersed in warm water to which a mild detergent has been added. Agitate the filter until clean, rinse and allow to dry before replacing.

HEPA Filters (High Efficiency Particle Arrestors)

This type of filter is generally fitted in front withdrawal frame. Filters will be held into the frame by retaining bars which can be removed to allow access to replace filters.

Carbon Filters

Carbon filters normally have an active life of about twelve (12) months, or more. It is advisable to remove a sample from the pack to return to manufacturer to determine the remaining working life, preferably after the first six (6) months & subsequent six (6) monthly intervals.

MOTE! WHEN REPLACING ALL FILTERS ENSURE FILTER IS FACING CORRECT DIRECTION AS INDICATED BY AN AIRFLOW ARROW.

ROUTINE MAINTENANCE SCHEDULE

	Monthly	3 Monthly	6 Monthly	Annually
Fan Shaft Bearings				
Motors				
Belts & Pulleys				
Elec. Heater Battery				
Coils				
Eliminators				
Dampers				
Panel & Bag Filters				
HEPA Filters				
Carbon Filters				
External Surfaces				

INVALIDATION OF GUARANTEE

The following misuses or maltreatment of AIR HANDLERS LIMITED equipment will render all guarantees, as set out on the Conditions of Sale, void.

- Failure to install, set up or put to work any part of the equipment as specified in AIR HANDLERS LIMITED Installation, Operation and Maintenance Instructions.
- Attempting to operate the motors and other electrical equipment with an electrical supply other than that designated on the motor nameplate, or failing to connect and protect such equipment in accordance with I.E.E. Regulations and local by-laws.
- Failure to notify AIR HANDLERS LIMITED of equipment damaged on receipt in writing within five (5) days.
- Failure to run equipment within the design specifications as notified at the time of order.
- Modifications to designed arrangement or performances without the prior written approval of AIR HANDLERS LIMITED.
- Damage caused to equipment on site through lack of adequate protection from the elements or misuse by other trades.
- Failure to observe all normally accepted engineering practices during installation, commissioning and subsequent operation of equipment.

AHU - HEALTH AND SAFETY REQUIREMENTS

Manufacturers Responsibility

Fan section access - All access doors allowing entry to the fan section are to be fitted with one lockable door handle to prevent unauthorised access. Additionally these doors are to display a suitable warning label.

Electric Heater access - Non lockable lift off electric heater access panels are to display a suitable electric warning label.

Specification - Additional safety guards and features (such as driveguard, fan inlet guards, bulkhead lights etc.) will be fitted when requested in the specification and included within our quotation.

Humidifiers - Copper steam pipework between humidifiers and distribution pipes where installed by ourselves will be lagged to prevent exposure of hot surfaces. When humidifier steam pipework installation is not carried out by ourselves it is the installers responsibility to ensure correct lagging.

Installers Responsibility

Installation - Unless otherwise specified by ourselves this product is supplied with the intention to be incorporated into other equipment or fitted into a ducted ventilation system or similar suitable application. Some installations may require additional safety parts to ensure safe operation. For example, fan fitted at the end of a ducted system with the inlet or outlet open exposing the impeller/motor to unguarded access. In this event the installer must fit a safety guard complying to current regulations.

Isolators - Isolators are to be fitted locally to all fan motors and other electrical components of the AHU to allow safe working on the equipment.

Humidifiers - See “Humidifiers” section above.

End Users responsibility

All AHU's are despatched with keys tied to door handles, it is the responsibility of the end user after hand-over to ensure that all keys are kept safe by a responsible person and only issued to authorised personnel.